

commercial products

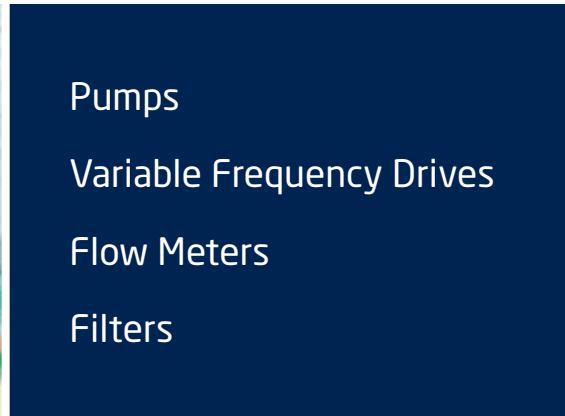

Pumps

Variable Frequency Drives

Flow Meters

Filters

WE BRING **WATER** TO LIFE.™

FEATURED PRODUCTS

FOR 2017

ALL NEW Automated Flow Systems™

Example 1:

- NEMA 4X VFD (directly mounted to motor)
- BADU Block Multi (vertical pump)
- Flow Meter
- Filter

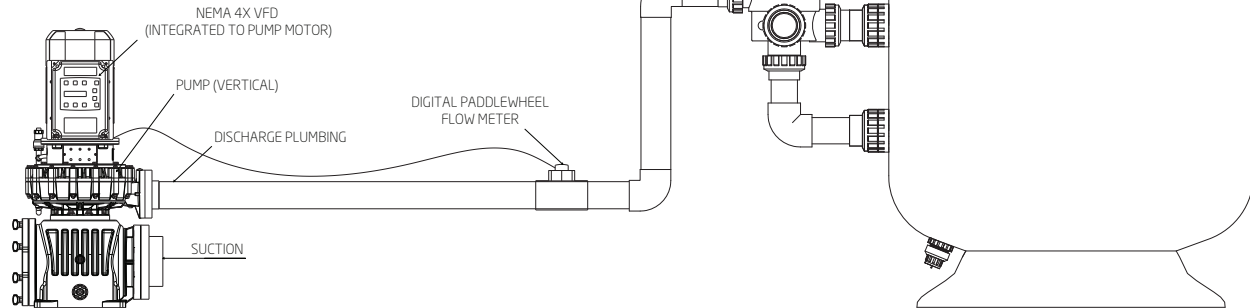

Example 2:

- NEMA 12 VFD (Wall mounted)
- Normblock Multi (horizontal pump)
- Flow Meter
- Filter

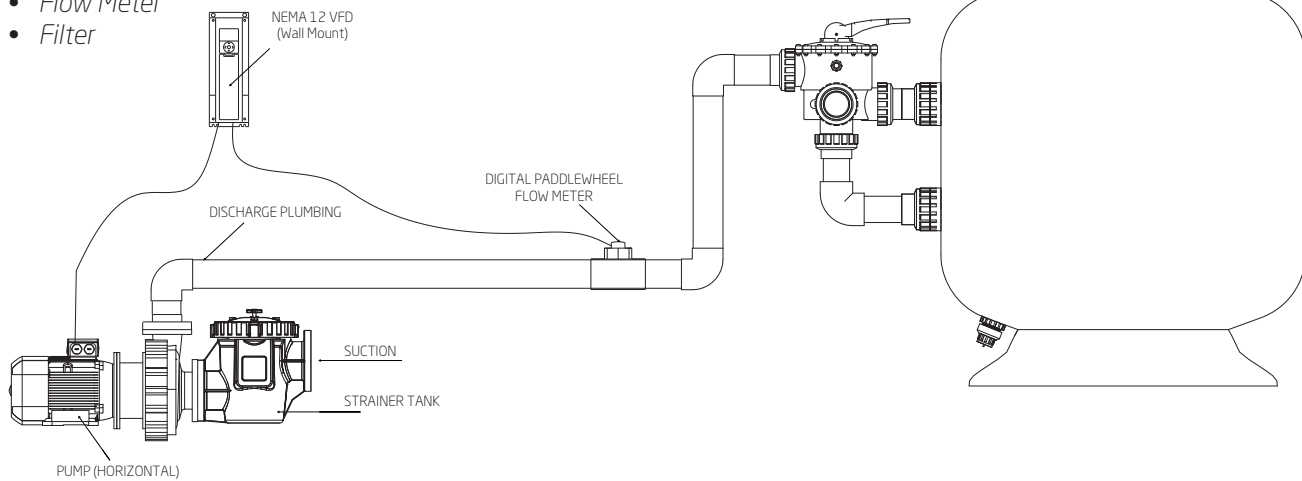

System Features

- Any configuration available
- Horizontal & Vertical pump models (3 Phase with TEFC motor):
 - BADU® Block Series (5 - 100 THP) (Cast Iron or Bronze)
 - Normblock Series (5 - 100 THP) (Cast Iron or Bronze)
 - BADU® Block Multi Series (7.5, 10, 15, & 20 THP) (All Plastic)
 - Normblock Multi Series (7.5, 10, 15, & 20 THP) (All Plastic)
 - Model 95 Series (5 & 7.5 THP) (All Plastic)
- Inline systems: Are available with optional strainer tank.
- The vertical pump can be rotated for ease of plumbing.
- NEMA 12 and stand alone NEMA 4x VFDs available. (NEMA 12 has Multi-pump Control)
- Digital flow meters synced with VFDs to manage flow as required while saving energy.
- Optional: Pump & VFD can be preprogrammed for plug-n-play.
- Complete line of filters & manifolds.

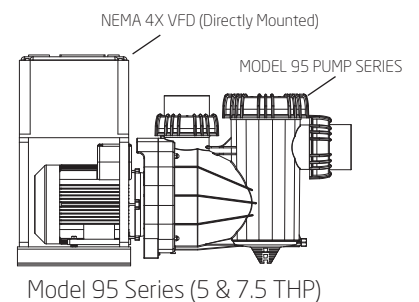
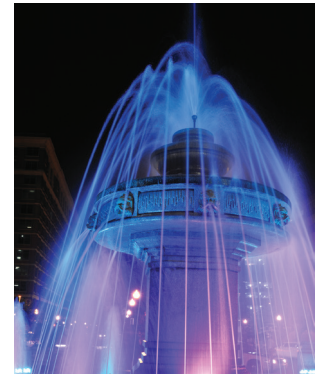
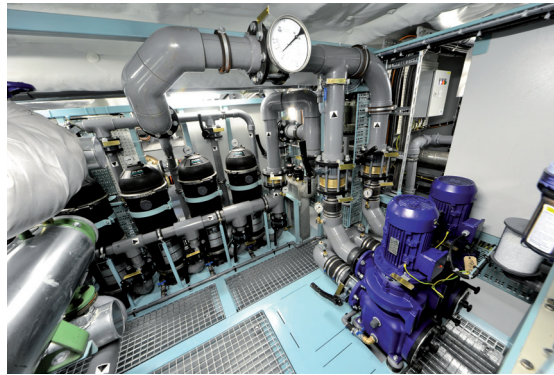

Table of Contents

Commercial Products

Model 72	4
BADU® EcoMV (<i>Variable Speed w/ SVRS</i>)	5
Model 433	6
Model 95	8
BADU® Block & Normblock Series (<i>Cast Iron or Bronze</i>)	10
BADU® Block & Normblock Multi Series (<i>All Plastic</i>)	12
Speck/Vacon 100 Flow Series (<i>NEMA 12</i>)	14
Speck/Vacon X5 Series (<i>NEMA 4</i>)	16
Digital Flow Meters	18
Equipment Packs	19
BKP	20
Filters	21



A Sampling of Speck Commercial Installations on Pools & Fountains Around the World

City of Chandler Aquatics

Chandler, Arizona USA
Swimming Pool

Glasgow High School

Newark, Delaware USA
Competition Pool

Plantation Oaks

Jacksonville, Florida USA
Swimming Pool

4 Seasons Hotel

Mauai, Hawaii USA
Swimming Pool

Navy Base

Pearl Harbor, Hawaii USA
Swimming Pool

Rainbow Beach Water Park

Vincennes, Indiana USA
Competition Pool

City of New Tazewell Municipal Pool

New Tazewell, Tennessee USA

Frisco Natatorium

Frisco, Texas USA
Competition Pool

Aquacentrum

Hradec, Czech Republic
Swimming Pool

Aqua Park

Krim, Ukraine
Swimming Pool

Hotel Alexandra

Molde, Norway
Swimming Pool

Vogesenplatz

Basel, Switzerland
Fountain

Freibad Nassua

Nassau, Germany
Fountain

Theresienbad

Vienna, Austria
Swimming Pool

Tierpark Hagenbeck

Hamburg, Germany
Artic Animals Exhibits

CNI Les Thermes

Strassen, Luxembourg
Swimming Pool

Aqua Park

Kfar, Israel
Swimming Pool

Messe Basel

Basel, Switzerland
Fountain

MODEL 72



High Performance, High Head Swimming Pool Pump

Features

- This high performance, high flow pump comes complete with our unique mechanical shaft seal that allows the pump, if mistreated, to run dry for up to one hour.
- The pump can be used for pool water with a salt concentration of up to 5000 ppm.
- Pump parts are made of 100% recyclable plastic. Non-corrosive, chemical/UV resistant, and can withstand temperatures of up to 175°F.
- Suction and discharge are equipped with 2" or 3" quick disconnect unions for easy installation and maintenance.
- For pool users' safety, the impeller has a dielectric shaft sleeve that provides absolute separation between pool water and electric parts.
- Lock ring that incorporates handles. These handles provide the user with a convenient way to easily remove the lid.
- Heavy duty "1081" E-plus®/extreme-E™ energy efficient motors for extra low energy consumption. This large 56 frame motor is thermally protected, has a PSC switchless design and extra large sealed ball bearings.
- Motor is easy to remove without disturbing the plumbing. Reusable o-rings throughout.
- Two year warranty on the motor and all pump parts, including normal wear of the mechanical seal.
- Every pump is performance tested before leaving the Speck factory.



Model 72-IV



Trademarks and Certifications



Applications

- In-ground pools
- Large residential and small commercial pools

Performance Curves

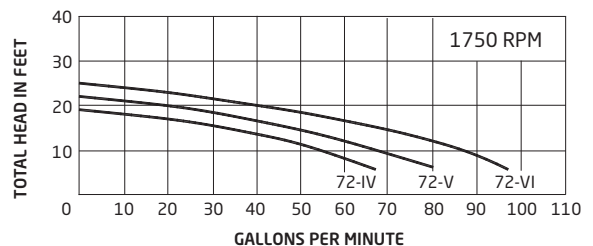
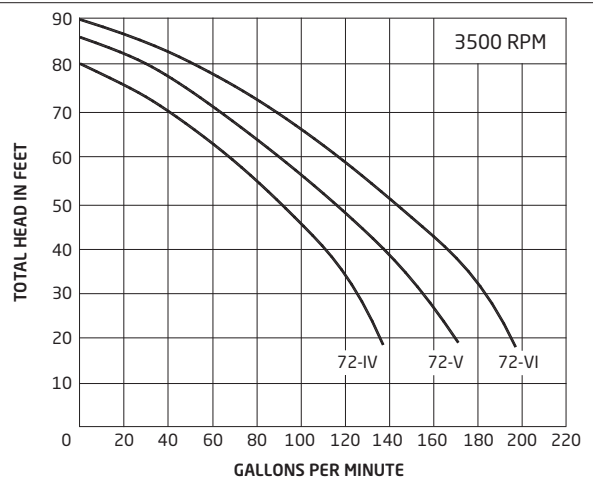

Dimensional Drawing

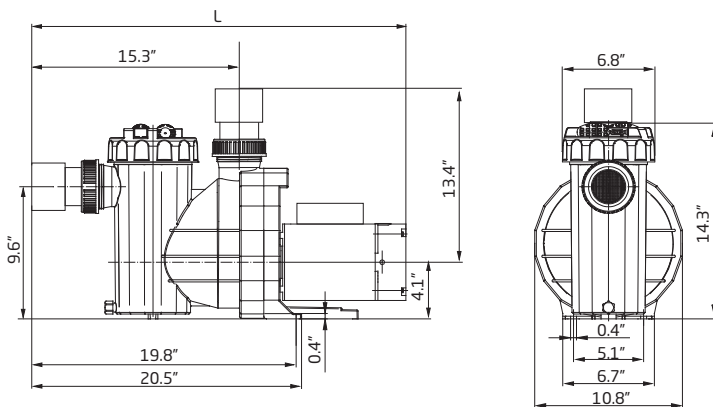

MODEL	DIMENSION "L"	SHIPPING WEIGHT
72-IV	29.0"	52 lbs.
72-V	29.0"	55 lbs.
72-VI	29.5"	56 lbs.

MODEL 72



High Performance, High Head Swimming Pool Pump



Pricing

Premium Energy Efficient Single Speed

Order #	Model #	HP	S.F.	THP	Volts	Motor/Frame	Speed	List Price
IG234-1200M-000	72-IV	1.5	1.50	2.25	115/208-230	EE*/56	single	\$1,074.00
IG234-1250M-000	72-V	2.0	1.30	2.60	208-230	EE*/56	single	1,097.00
IG234-1350M-000	72-VI	3.0	1.15	3.45	208-230	EE*/56	single	1,296.00

Premium Energy Efficient Two Speed

Order #	Model #	HP	S.F.	THP	Volts	Motor/Frame	Speed	List Price
IG231-2200M-000	72-IV	1.	1.47	2.25	230	EE*/PSC/56	2-speed	\$1,082.00
IG231-2250M-000	72-V	2.0	1.30	2.60	230	EE*/PSC/56	2-speed	1,241.00

All 2-speed motors comes equipped with HI/OFF/LO toggle switch.

*EE = Premium energy efficient motors.

Three Phase Single Speed (Full Rated)

Order #	Model #	HP	S.F.	THP	Volts	Motor/Frame	Speed	List Price
IG233-1150F-000	72-IV	1.5	1.30	1.95	208-230/460	3 phase/56	single	\$1,143.00
IG233-1200F-000	72-V	2.0	1.20	2.40	208-230/460	3 phase/56	single	1,191.00
IG233-1300F-000	72-VI	3.0	1.15	3.45	208-230/460	3 phase/56	single	1,319.00

Three phase units are not UL Listed and requires a motor starter.

Accessories

Order #	Description	List Price
2921116012B	Clear Lid with LED Light	\$ 41.20

Badu® EcoMV (2.7) Features

- 2.7 THP Century® V-Green® Variable Speed motor with built-in easy to use controller LCD screen. (Also available with SVRS)
- RPM levels can be set to range from 600 to 3450. The levels can be set in increments of 25.
- Programmable high efficiency TEFC (totally enclosed fan cooled) maintenance-free permanent magnet brushless 56 frame motor with Class F insulation.
- Freeze protection feature that can be turned ON/OFF or adjusted.
- Programmable auxiliary load feature.
- Adjustable screen contrast feature.
- Optional VLink™ WiFi pump controller allows you to easily monitor and manage your pool pump settings from a mobile device.



BADU EcoMV/72-V (SVRS)

Premium Energy Efficiency Variable Speed

Order #	Model #	THP	Volts	Motor/Frame	Speed	List Price
IG245-V270T-000	BADU EcoMV/72-V	2.7	230	EE*/TEFC/56	Variable speed	\$1,702.00
IG245-V270T-S00	BADU EcoMV/72-V (SVRS)	2.7	230	EE*/TEFC/56	Variable speed	1,850.00

*EE = Premium energy efficient motors.

MODEL 433



High Performance, High Head Swimming Pool Pump

Features

- This high performance, high head pump comes complete with our unique mechanical shaft seal that allows the pump, if mistreated, to run dry for up to one hour.
- The pump can be used for pool water with a salt concentration of up to 5000 ppm.
- Pump parts are made of 100% recyclable plastic. Non-corrosive, chemical/UV resistant, and can withstand temperatures of up to 175°F.
- Suction and discharge are reinforced with aluminum rings.
- For pool users' safety, the impeller has a dielectric shaft sleeve that provides absolute separation between pool water and electric parts.
- Lock ring that incorporates handles. These handles provide the user with a convenient way to easily remove the lid.
- Flooded suction models available.
- Heavy duty "1081" pool motor with large 56 frame is thermally protected, has a PSC switchless design and extra large sealed ball bearings.
- Available with E-plus®/extreme-E® energy efficient motors for extra low energy consumption.
- Motor is easy to remove without disturbing the plumbing. Reusable o-rings throughout.
- Two year warranty on the motor and all pump parts, including normal wear of the mechanical seal.
- Every pump is performance tested before leaving the Speck factory.

Dimensional Drawing

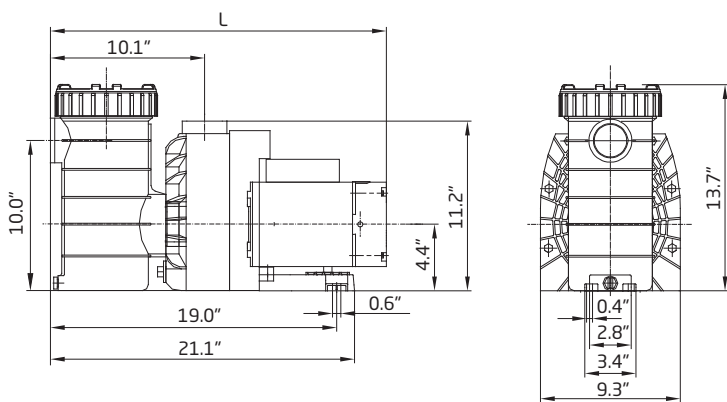

MODEL	DIMENSION "L"	SHIPPING WEIGHT
433-I	24.8"	37 lbs.
433-II	24.8"	39 lbs.
433-III	25.8"	40 lbs.
433-IV	26.0"	44 lbs.
433-V	26.3"	54 lbs.
433-VI	26.8"	56 lbs.



Model 433-V



Trademarks and Certifications



Applications

- In-ground pools
- Pool/Spa Combinations

Performance Curves

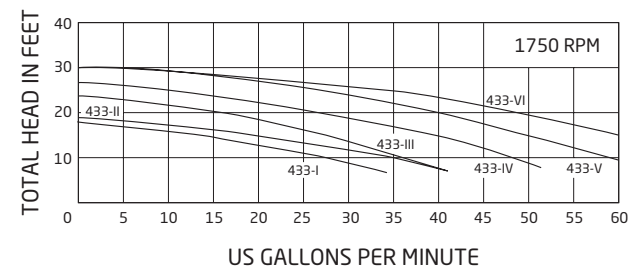
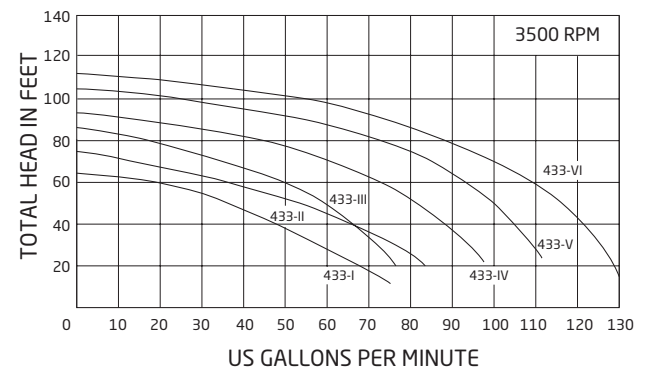

MODEL 433



High Performance, High Head Swimming Pool Pump



Pricing

Standard Efficiency Single Speed (Max Rated)

Order #	Model #	HP	S.F.	THP	Volts	Motor/Frame	Speed	List Price
IG111-1075M-000	433-I	0.75	1.25	0.98	115/230	PSC/56	single	\$ 847.00
IG111-1100M-000	433-II	1.0	1.25	1.25	115/230	PSC/56	single	865.00
IG111-1150M-000	433-III	1.5	1.10	1.65	115/230	PSC/56	single	925.00
IG111-1200M-000	433-IV	2.0	1.10	2.25	115/230	PSC/56	single	1,065.00

Premium Energy Efficient Single Speed

Order #	Model #	HP	S.F.	THP	Volts	Motor/Frame	Speed	List Price
IG114-1075M-000	433-I	0.5	1.95	0.98	115/208-230	EE*/56	single	\$ 910.00
IG114-1100M-000	433-II	0.75	1.67	1.25	115/208-230	EE*/56	single	950.00
IG114-1150M-000	433-III	1.0	1.65	1.65	115/208-230	EE*/56	single	995.00
IG114-1200M-000	433-IV	1.5	1.50	2.25	115/208-230	EE*/56	single	1,111.00
IG114-1250M-000	433-V	2.0	1.30	2.60	208-230	EE*/56	single	1,210.00
IG114-1350M-000	433-VI	3.0	1.15	3.45	208-230	EE*/56	single	1,374.00

Premium Energy Efficient Two Speed

Order #	Model #	HP	S.F.	THP	Volts	Motor/Frame	Speed	List Price
IG111-2100M-000	433-II	0.75	1.67	1.25	115	EE*/56	2-speed	\$1,095.00
IG119-2100M-000	433-II	0.75	1.67	1.25	230	EE*/PSC/56	2-speed	1,095.00
IG111-2150M-000	433-III	1.0	1.65	1.65	230	EE*/PSC/56	2-speed	1,126.00
IG111-2200M-000	433-IV	1.5	1.47	2.25	230	EE*/PSC/56	2-speed	1,216.00
IG111-2250M-000	433-V	2.0	1.30	2.60	230	EE*/PSC/56	2-speed	1,457.00

All 2-speed motors come equipped with HI/OFF/LO toggle switch.

Three Phase Single Speed (Full Rated)

Order #	Model #	HP	S.F.	THP	Volts	Motor/Frame	Speed	List Price
IG113-1050F-000	433-I	0.5	1.60	0.8	208-230/460	3 phase/56	single	\$ 925.00
IG113-1075F-000	433-II	0.75	1.50	1.125	208-230/460	3 phase/56	single	963.00
IG113-1100F-000	433-III	1.0	1.40	1.40	208-230/460	3 phase/56	single	1,035.00
IG113-1150F-000	433-IV	1.5	1.30	1.95	208-230/460	3 phase/56	single	1,137.00
IG113-1200F-000	433-V	2.0	1.20	2.40	208-230/460	3 phase/56	single	1,265.00
IG113-1300F-000	433-VI	3.0	1.15	3.45	208-230/460	3 phase/56	single	1,409.00

Three phase units are not UL Listed and requires a motor starter.

*EE = Premium energy efficient motors.

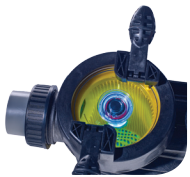

Clear Lid with a built-in LED light for easier viewing of critters and debris in low light conditions.

Accessories

Order #	Description	List Price
2921116012B	Clear Lid with LED Light	\$ 41.20

MODEL 95



High Performance Plastic Commercial Pool Pump

Features

- Largest one-piece housing design with integrated strainer basket and easy on/off two piece lid.
- Quiet and efficient medium head pump performance.
- This high performance pump comes complete with our unique mechanical shaft seal that allows the pump, if mistreated, to run dry for up to one hour.
- The pump can be used for pool water with a salt concentration of up to 5000 ppm.
- Suction and discharge are equipped with 4" quick disconnect unions for easy installation and maintenance.
- Wrench for unions and lid is included with each pump. Flanges are available on request.
- Available with a heavy duty energy efficient totally enclosed fan cooled (TEFC) or Open Drip Proof (ODP) motor designs. (*Model 95-IX & Model 95-X requires a motor starter.*)
- Motor is easy to remove without disturbing the plumbing. Reusable o-rings throughout.
- Two year warranty on the motor and all pump parts, including normal wear of the mechanical seal.
- Every pump is performance tested before leaving the Speck factory.



Model 95-X



Trademarks and Certifications



Applications

- In-ground pools
- High rate sand filter applications
- Water Features

Performance Curves

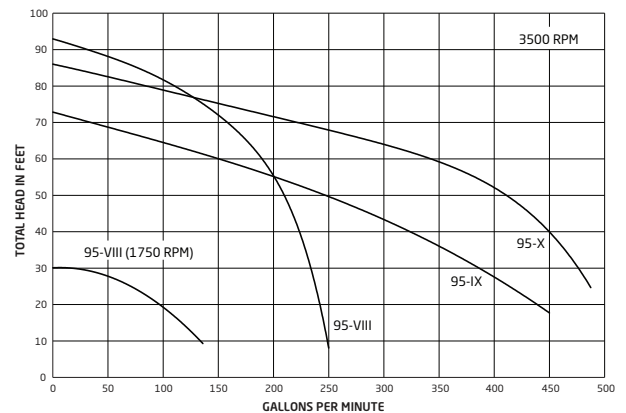

Dimensional Drawing

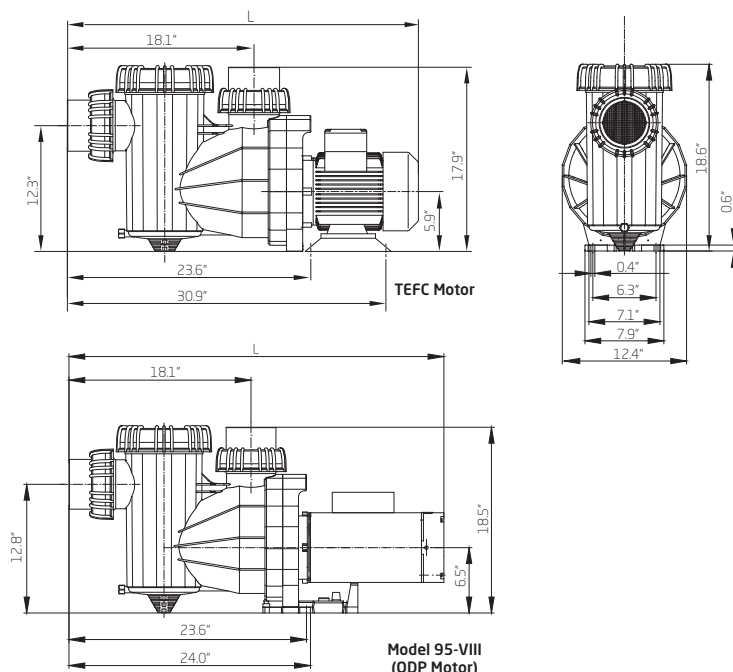

MODEL	DIMENSION "L"	SHIPPING WEIGHT
95-VIII	36.8"	75 lbs.
95-IX	36.5"	140 lbs.
95-IX (3PH)	34.0"	100 lbs.
95-X (3PH)	36.5"	141 lbs.

MODEL 95



High Performance Plastic Commercial Pool Pump



Pricing

Energy Efficient Single Speed

Order #	Model #	HP	S.F.	THP	Volts	Motor/Frame	Speed	List Price
IG274-1500M-000	95-VIII	4.0	1.25	5.0	208-230	EE*/ODP/56	single	\$2,169.00
IG274-1500F-000	95-IX	5.0	1.15	5.75	208-230	EE*/TEFC/112M	single	3,278.00
IG274-1750F-000	95-X	7.5	1.15	8.625	208-230	EE*/TEFC/112M	single	4,226.00

Premium Energy Efficient Two Speed

Order #	Model #	HP	S.F.	THP	Volts	Motor/Frame	Speed	List Price
IG271-2500M-000	95-VIII	4.0	1.25	5.0	230	EE*/ODP/56	2-speed	\$2,291.00

Three Phase Single Speed (Full Rated)

Order #	Model #	HP	S.F.	THP	Volts	Motor/Frame	Speed	List Price
IG273-1500M-000	95-VIII	4.0	1.25	5.0	208-230/460	ODP/56	single	\$2,281.00
IG273-1500F-000	95-IX	5.0	1.15	5.75	208-230/460	TEFC/112M	single	2,969.00
IG273-1750F-000	95-X	7.5	1.15	8.625	208-230/460	TEFC/112M	single	3,296.00

*EE = Premium energy efficient motors.

NOTE: Models 95-VIII single phase and Model 95-VIII 2-speed are thermally protected. All other models requires a motor starter.



Speck offers a full line of motor starters for 0.5 to 7.5 HP, either single or three phase.

The Wrench offers a convenient and efficient way to open the strainer tank. The wrench also doubles as a tool to use on 3" & 4" unions.



Accessories

Order #	Description	List Price
2902099800	Lid and Union wrench	\$ 48.90
25V24AXRM34	Motor starter, 5.0 HP, S.F. 1.15, 208-230V, single phase, Nema 4X, (Model 95-IX)	253.20
18V24AXR32	Motor starter, 5.0 HP, S.F. 1.15, 208-230V, 3 phase, Nema 4X (Model 95-IX)	241.80
50V24AXRM38	Motor starter, 7.5 HP, S.F. 1.15, 208-230V, single phase, Nema 4X (Model 95-X)	407.40
25V24AXR33	Motor starter, 7.5 HP, S.F. 1.15, 208-230V, 3 phase, Nema 4X (Model 95-X)	273.90

Additional high voltage models available upon request. Motor Starters are UL Listed in Canada and the United States. For others, please call Speck Customer Service at (800) 223-8538.



Model 95 VS

The Model 95 VS incorporates an onboard NEMA 4x Speck / Vacon VFD providing variable speed technology in any corrosive environments. The Unit can be connected to a flow meter to provide constant flow.



BADU® Block & Normblock Series



Cast Iron or Bronze Commercial Pump 1750 RPM

Features

- This pump has a vertical design that creates impressive performance while saving space thereby reducing construction costs.
- After installation, the discharge connection can be rotated freely. (A major advantage at the construction site.)
- Heavy duty energy efficient totally enclosed fan cooled (TEFC) motor, Class F insulation, protection class IP 55. Sealed ball bearings need no lubrication.
- Superior design reduces vibrations resulting in quiet operation. (The noise level from both the motor and pump are greatly influenced by how they are installed. Consideration should be given to minimize vibration and noise transmission.)
- The motor can be replaced without disassembling the pump. This design allows for the mechanical seal to remain in place.
- A high wear and rugged tungsten-carbide mechanical seal allows for a long life and long maintenance intervals.
- Each pump is equipped with outside circulation/air bleed piping, and includes an air valve, for automatic and manual air bleeding resulting in a long life of the mechanical seal.
- The closed impellers are individually balanced, providing smooth running conditions and guarantees a long operation life of the entire pump assembly.
- The inside of the strainer tank is coated with a dirt and corrosion resistant enamel.
- Stainless steel shaft with 316 stainless steel protective shaft sleeve.
- The pump is available in cast iron or bronze.
- The Badu Block comes with a full 12 month warranty.
- Every pump is tested to factory & customer's specifications.



Badu Block 100/250

Trademarks and Certifications



Applications

- Ideally suited for aquatic facilities, fountains, water parks, aquaculture, and pools with elevated salt concentration.

Performance Curves

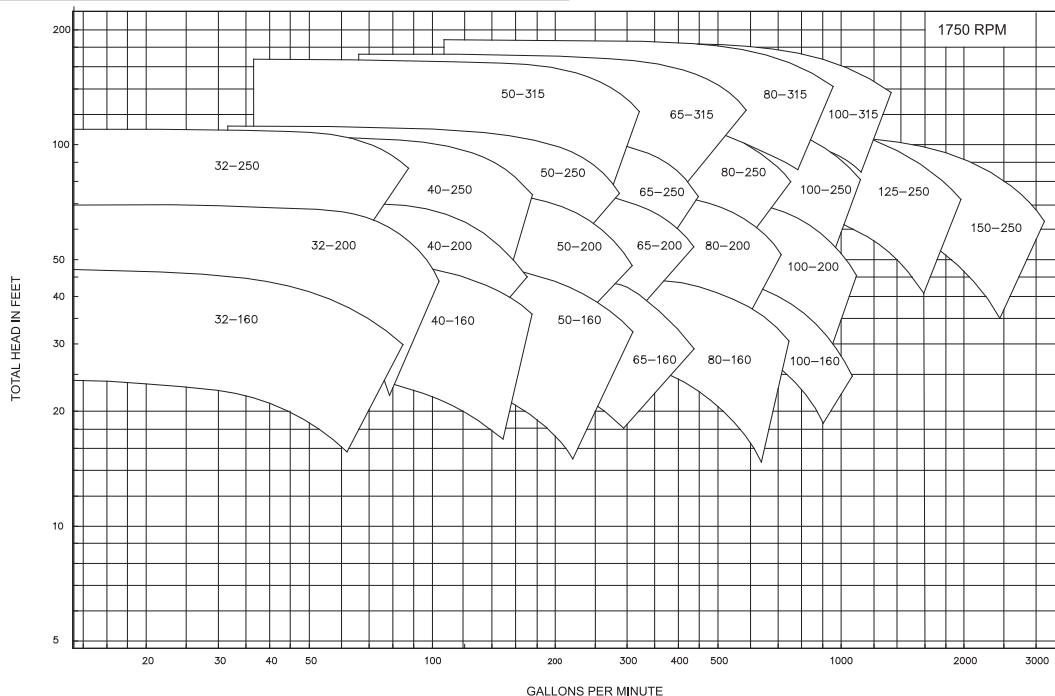

BADU® Block & Normblock Series



Cast Iron or Bronze Commercial Pump 1750 RPM

Pricing

Order #	Description	List Price
Call for part number	Badu Block, large vertically positioned single-stage centrifugal pump. Ranging from 5.0 to 100 HP, with TEFC 3 phase motor, with built-in strainer.	On request
Call for part number	Normblock, horizontally positioned single-stage centrifugal pump. Ranging from 5.0 to 100 HP, with TEFC 3 phase motor.	On request

Speck offers many different options for this pump, please call Speck Customer Service at (800) 223-8538 for a quote.

Below is the information Speck Pumps will need to determine the best pump for your application:

- Type of application: Commercial pools, water parks, water features, etc.
- Self-priming or flooded suction
- Gallons per minute (GPM)
- Total dynamic head (TDH)
- Net positive suction head (NPSH)
- 1750 or 3500 RPM motor at 60Hz
- 1450 or 2900 RPM motor at 50Hz
- Voltage, Cycles
- Type and size of connection
- Bronze or Cast Iron
- NSF 50 requirement

Additional Items

Normblock Pump Horizontal without strainer tank

The Normblock pumps have a robust horizontal single-stage design. The block design delivers impressive circulation performance at minimal space requirements. This commercial pool pump is perfectly suited for aquatic facilities, pools, spas, waterparks, fountains, and lazy rivers. The Normblock pumps have been developed from our Standard Pump series and proven over decades of service.

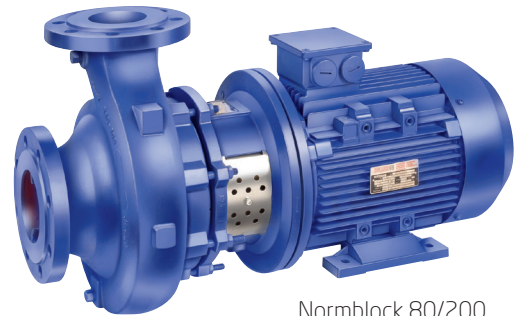

Normblock 80/200

BADU® Select

With the Badu Select program, choosing the right Speck pump for the job is only a few clicks away. Speck makes it easy to find the right pump. This program offers engineering specifications, pump drawings and schematics, customized bid sheets and pump flow curves.



Every pump is performance-tested to factory and customer specifications.

BADU® Block & Normblock Multi Series



All Plastic Commercial Pump 1750 RPM

Features

- Superior slow (1750 rpm) running design reduces vibrations resulting in quiet operation.
- After installation, the discharge connection can be rotated freely. *(A major advantage at the construction site.)*
- The housing is made of high performance plastic (THK), corrosion resistant without elaborate internal coating and can be used with higher brine concentrations.
- Heavy duty energy efficient totally enclosed fan cooled (TEFC) motor, Class F insulation, protection class IP 55. Sealed ball bearings need no lubrication.
- The motor can be replaced without disassembling the pump. This design allows for the mechanical seal to remain in place.
- A high wear and rugged SIC/SIC - HNBR mechanical seal allows for a long life and long maintenance intervals
- The closed impellers are individually balanced, providing smooth running conditions and guarantees a long operation life of the entire pump assembly.
- Stainless steel shaft with 316 stainless steel protective shaft sleeve.
- The pump comes with a full 12 month warranty.
- Every pump is tested to factory & customer's specifications.

Please Note: The noise level from both the motor and pump are greatly influenced by how they are installed. Consideration should be given to minimize vibration and noise transmission.

Features Specific to BADU Block Multi Series

- This pump has a vertical design that creates impressive performance while saving space thereby reducing construction costs.
- All plastic strainer tank with stainless steel basket. *(Optional plastic basket available).*
- Each pump is equipped with outside circulation/air bleed piping, and includes an air valve, for automatic and manual air bleeding resulting in a long life of the mechanical seal.
- Optional integrated NEMA 4X Speck / Vacon VFD.

Features Specific to Normblock Multi Series

- This pump has a robust horizontal single stage design.
- Optional all plastic strainer tank for horizontal flooded suction applications.



Normblock 65/250

BADU Block 100/250

Trademarks and Certifications



Applications

- Ideally suited for aquatic facilities, fountains, water parks, and pools with elevated salt concentration.
- Perfect for aquaculture.



BADU Block with integrated NEMA 4X Speck / Vacon VFD.

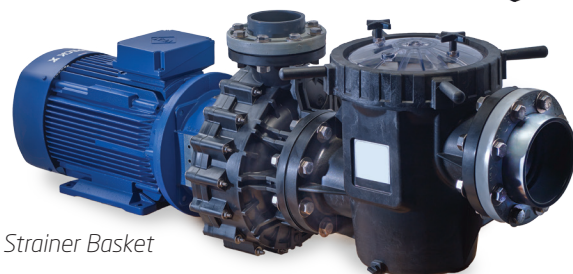

Normblock with Strainer Basket

BADU® Block & Normblock Multi Series



All Plastic Commercial Pump 1750 RPM

Performance Curves

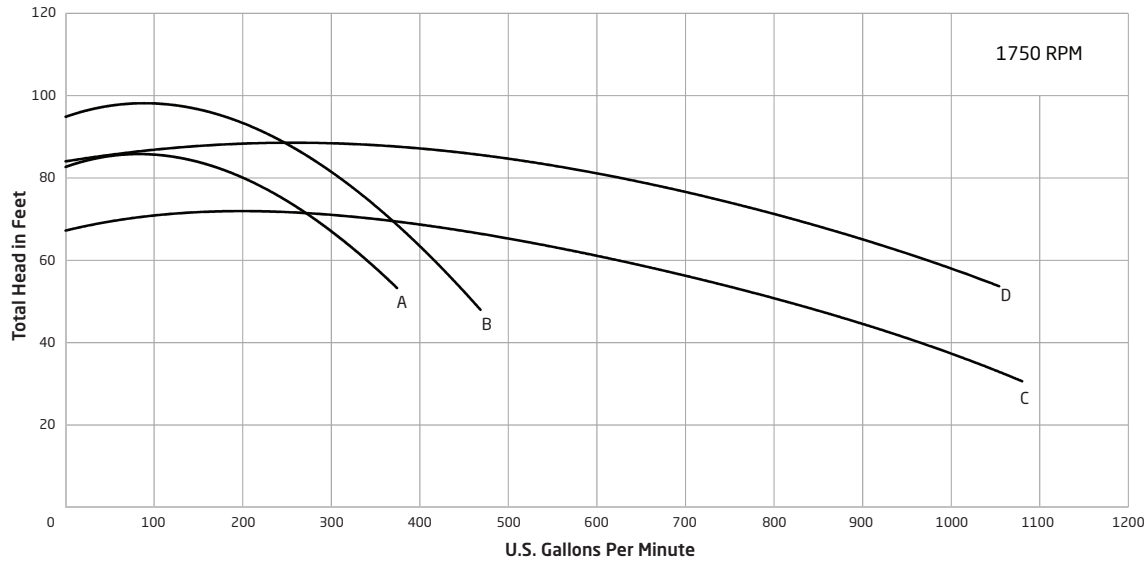

A. 65/250 (Ø 225mm) - 7.5 HP S.F. 1.25
 B. 65/250 (Ø 240mm) - 10 HP S.F. 1.25

C. 100/250 (Ø 220mm) - 15 HP S.F. 1.25
 D. 100/250 (Ø 240mm) - 20 HP S.F. 1.00

Pricing

BADU Block Multi Series

Order #	Model	HP	S.F.	Motor Data (Phase; Voltage)	Flange Sizes* Suction/Discharge	List Price
BB705-1007F-000	65/250	7.5	1.25	3 PH; 60 Hz; 208-230/460 V; TEFC	ANSI 6" / ANSI 3"	\$ 5,975.00
BB705-1010F-000	65/250	10	1.25	3 PH; 60 Hz; 208-230/460 V; TEFC	ANSI 6" / ANSI 3"	6,375.00
BB705-1015F-000	100/250	15	1.25	3 PH; 60 Hz; 208-230/460 V; TEFC	ANSI 8" / ANSI 4"	9,431.00
BB705-1020F-000	100/250	20	1.00	3 PH; 60 Hz; 208-230/460 V; TEFC	ANSI 8" / ANSI 4"	9,851.00

*NOTE: Flange Kits are sold separately.

Normblock Multi Series

Order #	Model	HP	S.F.	Motor Data (Phase; Voltage)	Flange Sizes* Suction/Discharge	List Price
NB715-1007F-000	65/250	7.5	1.25	3 PH; 60 Hz; 208-230/460 V; TEFC	ANSI 4" / ANSI 3"	\$ 4,600.00
NB715-1010F-000	65/250	10	1.25	3 PH; 60 Hz; 208-230/460 V; TEFC	ANSI 4" / ANSI 3"	5,000.00
NB715-1015F-000	100/250	15	1.25	3 PH; 60 Hz; 208-230/460 V; TEFC	ANSI 6" / ANSI 4"	7,405.00
NB715-1020F-000	100/250	20	1.00	3 PH; 60 Hz; 208-230/460 V; TEFC	ANSI 6" / ANSI 4"	7,825.00

*NOTE: Flange Kits are sold separately.

Normblock Accessories

Order #	Description	List Price
7363409031	Strainer Tank & Hardware for Normblock Model 65/250 (4" Suction / 4" Union Connection)	\$ 906.00
7319B05008	Strainer Tank & Hardware for Normblock Model 100/250 (6" Suction / 6" Pump Connection)	1,012.00

Flange Kits

Order #	Description	List Price
7300000040A	ANSI 3" Flange Kit - Includes two-pieces ANSI class 150 flange, gasket and stainless steel bolts	\$ 118.00
7300000034A	ANSI 4" Flange Kit - Includes two-pieces ANSI class 150 flange, gasket and stainless steel bolts	155.50
7300000036A	ANSI 6" Flange Kit - Includes two-pieces ANSI class 150 flange, gasket and stainless steel bolts	237.40
7300000038A	ANSI 8" Flange Kit - Includes two-pieces ANSI class 150 flange, gasket and stainless steel bolts	312.00

SPECK / VACON 100 Flow Series



Variable Frequency Drive

Features

- The Vacon 100 series is designed to meet and exceed even the most stringent requirement of the commercial pool industry.
- Does not require a factory technician to be commissioned.
- Guided Start-Up: Simplifies initial programming
- Motor and Drive are protected against voltage spikes, phase imbalance and power surges.
- Real time clock feature
- Efficiency ratings greater than 98%
- Smooth motor acceleration/deceleration
- Overload trip protection
- Built-in memory
- Drive included all necessary hardware, I/O and communication features without the need to purchase any additional equipment
- LCD graphical keypad with intuitive wizards, built-in help text, and a user friendly interface.
- Speck Vacon 100 series have a typical 10 years or more service life, reducing maintenance cost and are environmentally friendly for easy recycling.
- The VFD comes with a full 12 month warranty.

Optional Integrated Drive Supply Switch: (for 0.8 HP - 30 HP)

- The drive's main supply can be disconnected and locked during maintenance work. Provides safety during maintenance.
- Saves on investment costs and space. The added cost of a separate box is eliminated.
- PID controllers for accurate process control.
- Intergrated Harmonics Filters

Vacon 100 Flow Series
with Switch



Trademarks and Certifications



Applications

- Perfect match for commercial pools (indoor & outdoors)
- Nema 12

Technical Data

FRAME SIZE	HEIGHT "H"	WIDTH "W"	DEPTH "D"	SHIPPING WEIGHT
MR4	12.9"	5.0"	7.5"	13 lbs.
MR5	16.5"	5.7"	8.4"	22 lbs.
MR6	21.9"	7.7"	9.0"	44 lbs.
MR7	26.0"	9.3"	10.2"	83 lbs.
MR8	38.0"	11.4"	13.5"	146 lbs.
MR9	45.3"	18.9"	14.4"	238 lbs.

NOTE: For models with the switch add 5" to the Depth (D)

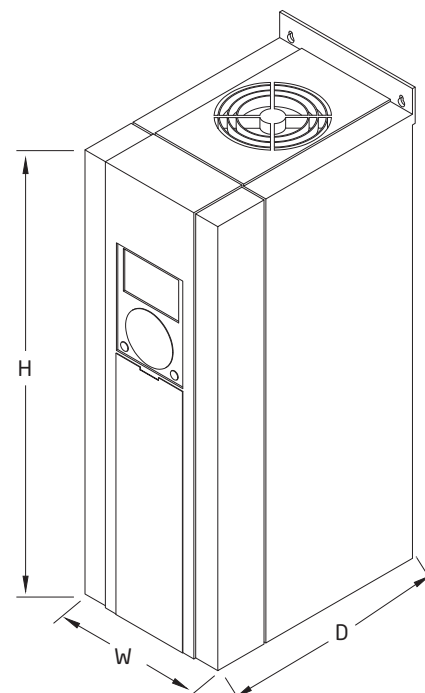

SPECK / VACON 100 Flow Series



Variable Frequency Drive

Pricing

Models without the Integrated Drive Supply Switch

Three Phase input to Three Phase output, 50/60 Hz

Order #	Model #	Enclosure	HP	Amps	Volts	Frame Size	List Price
2971540032F	VFD	NEMA 12	0.75	3.7	208-240	MR4	\$1,710.00
2971540042F	VFD	NEMA 12	1.0	4.8	208-240	MR4	1,751.00
2971540072F	VFD	NEMA 12	1.5	6.6	208-240	MR4	1,808.00
2971540082F	VFD	NEMA 12	2.0	8.0	208-240	MR4	1,905.00
2971540112F	VFD	NEMA 12	3.0	11.0	208-240	MR4	2,089.00
2971540182F	VFD	NEMA 12	5.0	18.0	208-240	MR5	2,531.00
2971540242F	VFD	NEMA 12	7.5	24.0	208-240	MR5	2,839.00
2971540312F	VFD	NEMA 12	10.0	31.0	208-240	MR5	3,356.00
2971540482F	VFD	NEMA 12	15.0	48.0	208-240	MR6	4,586.00
2971540622F	VFD	NEMA 12	20.0	62.0	208-240	MR6	5,475.00
2971540752F	VFD	NEMA 12	25.0	75.0	208-240	MR7	6,998.00
2971540882F	VFD	NEMA 12	30.0	88.0	208-240	MR7	8,006.00
2971540035F	VFD	NEMA 12	1.5	3.4	380-500	MR4	1,650.00
2971540045F	VFD	NEMA 12	2.0	4.8	380-500	MR4	1,781.00
2971540055F	VFD	NEMA 12	3.0	5.6	380-500	MR4	1,909.00
2971540095F	VFD	NEMA 12	5.0	9.6	380-500	MR4	2,314.00
2971540125F	VFD	NEMA 12	7.5	12.0	380-500	MR4	2,591.00
2971540165F	VFD	NEMA 12	10.0	16.0	380-500	MR5	3,064.00
2971540235F	VFD	NEMA 12	15.0	23.0	380-500	MR5	3,701.00
2971540315F	VFD	NEMA 12	20.0	31.0	380-500	MR5	4,421.00
2971540385F	VFD	NEMA 12	25.0	38.0	380-500	MR6	5,854.00
2971540465F	VFD	NEMA 12	30.0	46.0	380-500	MR6	6,694.00

*Please check amps on the nameplate of the motor.

Additional Models (40 HP up to 125 HP) are available upon request. Please call Speck Customer Service at (800) 223-8538.

Models with the Integrated Drive Supply Switch

Three Phase input to Three Phase output, 50/60 Hz

Order #	Model #	Enclosure	HP	Amps	Volts	Frame Size	List Price
2971540032FS	VFD	NEMA 12	0.8	3.7	208-240	MR4	\$2,186.00
2971540042FS	VFD	NEMA 12	1.0	4.8	208-240	MR4	2,228.00
2971540072FS	VFD	NEMA 12	1.5	6.6	208-240	MR4	2,280.00
2971540082FS	VFD	NEMA 12	2.0	8.0	208-240	MR4	2,423.00
2971540112FS	VFD	NEMA 12	3.0	11.0	208-240	MR4	2,565.00
2971540182FS	VFD	NEMA 12	5.0	18.0	208-240	MR5	3,184.00
2971540242FS	VFD	NEMA 12	7.5	24.0	208-240	MR5	3,488.00
2971540312FS	VFD	NEMA 12	10.0	31.0	208-240	MR5	4,009.00
2971540482FS	VFD	NEMA 12	15.0	48.0	208-240	MR6	5,378.00
2971540622FS	VFD	NEMA 12	20.0	62.0	208-240	MR6	6,266.00
2971540752FS	VFD	NEMA 12	25.0	75.0	208-240	MR7	7,909.00
2971540882FS	VFD	NEMA 12	30.0	88.0	208-240	MR7	8,918.00
2971540035FS	VFD	NEMA 12	1.5	3.4	380-500	MR4	2,126.00
2971540045FS	VFD	NEMA 12	2.0	4.8	380-500	MR4	2,258.00
2971540055FS	VFD	NEMA 12	3.0	5.6	380-500	MR4	2,385.00
2971540095FS	VFD	NEMA 12	5.0	9.6	380-500	MR4	2,790.00
2971540125FS	VFD	NEMA 12	7.5	12.0	380-500	MR4	3,068.00
2971540165FS	VFD	NEMA 12	10.0	16.0	380-500	MR5	3,713.00
2971540235FS	VFD	NEMA 12	15.0	23.0	380-500	MR5	4,354.00
2971540315FS	VFD	NEMA 12	20.0	31.0	380-500	MR5	5,070.00
2971540385FS	VFD	NEMA 12	25.0	38.0	380-500	MR6	6,641.00
2971540465FS	VFD	NEMA 12	30.0	46.0	380-500	MR6	7,481.00

SPECK / VACON X5 SERIES



Variable Frequency Drive

Features

- The Vacon X5 series is designed for harsh environments without the need for an additional enclosure.
- Does not require a factory technician to be commissioned.
- Guided Start-Up: Simplifies initial programming
- Motor and Drive are protected against voltage spikes, phase imbalance and power surges.
- Real time clock feature
- Efficiency ratings greater than 98%
- Smooth motor acceleration/deceleration
- Overload trip protection
- Built-in memory
- Drive included all necessary hardware, I/O and communication features without the need to purchase any additional equipment
- LCD graphical keypad with intuitive wizards, built-in help text, and a user friendly interface.
- Speck Vacon X5 series have a typical 20 years or more service life, reducing maintenance cost and are environmentally friendly for easy recycling.
- The VFD comes with a 3 year warranty.



Trademarks and Certifications



Applications

- Perfect match for commercial pools (indoor & outdoors)
- Nema 4X

Technical Data

FRAME SIZE	HEIGHT "H"	WIDTH "W"	DEPTH "D"	SHIPPING WEIGHT
F0	9.47"	6.50"	6.08"	9 lbs.
F1	12.01"	8.72"	6.51"	14 lbs.
F2	17.38"	10.75"	7.91"	30 lbs.
F3	20.19"	11.19"	11.73"	50 lbs.
F4	29.35"	12.84"	13.80"	95 lbs.
F5	50.77"	16.31"	16.88"	305 lbs.

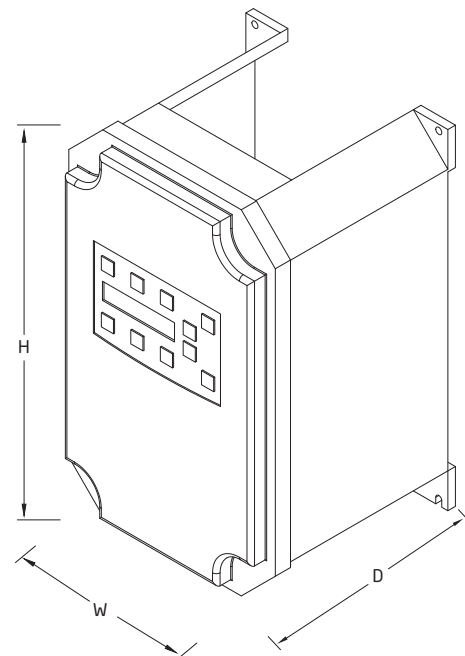

SPECK / VACON X5 SERIES



Variable Frequency Drive

Pricing

Single Phase input to Three Phase output, 200-230 VAC

Order #	Model #	Enclosure	HP	kW	Amps	Frame Size	List Price
29752S0050	VFD	IP66/NEMA 4X	5.0		15.2	F1	\$3,848.00
29752S0100	VFD	IP66/NEMA 4X	10.0		28.0	F2	5,314.00

Three Phase input to Three Phase output, 200-230 VAC

Order #	Model #	Enclosure	HP	kW	Amps	Frame Size	List Price
2975201009	VFD	IP66/NEMA 4X	1.0	0.75	4.2	F0	\$2,306.00
2975202009	VFD	IP66/NEMA 4X	2.0	1.5	6.8	F0	2,629.00
2975203009	VFD	IP66/NEMA 4X	3.0	2.2	9.6	F0	2,891.00
2975205009	VFD	IP66/NEMA 4X	5.0	4.0	15.2	F1	3,581.00
2975207509	VFD	IP66/NEMA 4X	7.5	5.5	22.0	F1	4,155.00
2975210009	VFD	IP66/NEMA 4X	10.0	7.5	28.0	F2	4,946.00
2975215009	VFD	IP66/NEMA 4X	15.0	11.0	42.0	F2	6,139.00
2975200200	VFD	IP66/NEMA 4X	20.0	15.0	54.0	F3	8,145.00
2975200250	VFD	IP66/NEMA 4X	25.0	18.5	68.0	F3	9,986.00

Three Phase input to Three Phase output, 380-480 VAC

Order #	Model #	Enclosure	HP	kW	Amps	Frame Size	List Price
2975401009	VFD	IP66/NEMA 4X	1.0	0.75	2.1	F0	\$2,408.00
2975402009	VFD	IP66/NEMA 4X	2.0	1.5	3.4	F0	2,756.00
2975403009	VFD	IP66/NEMA 4X	3.0	2.2	4.8	F0	3,045.00
2975405009	VFD	IP66/NEMA 4X	5.0	4.0	7.6	F1	3,754.00
2975407509	VFD	IP66/NEMA 4X	7.5	5.5	11.0	F1	4,350.00
2975410009	VFD	IP66/NEMA 4X	10.0	7.5	14.0	F1	5,003.00
2975415009	VFD	IP66/NEMA 4X	15.0	11.0	21.0	F2	5,955.00
2975420009	VFD	IP66/NEMA 4X	20.0	15.0	27.0	F2	7,118.00
2975425009	VFD	IP66/NEMA 4X	25.0	18.5	34.0	F2	8,828.00
2975430009	VFD	IP66/NEMA 4X	30.0	22.0	40.0	F2	10,913.00
2975400400	VFD	IP66/NEMA 4X	40.0	30.0	52.0	F3	13,920.00
2975400500	VFD	IP66/NEMA 4X	50.0	37.0	65.0	F3	17,468.00
2975400600	VFD	IP66/NEMA 4X	60.0	45.0	77.0	F4	22,035.00
2975400750	VFD	IP66/NEMA 4X	75.0	55.0	96.0	F4	25,020.00
2975401000	VFD	IP66/NEMA 4X	100.0	75.0	124.0	F4	28,691.00
2975401250	VFD	IP66/NEMA 4X	120.0	90.0	156.0	F5	32,595.00
2975401500	VFD	IP66/NEMA 4X	150.0	110.0	180.0	F5	35,809.00
2975402000	VFD	IP66/NEMA 4X	200.0	132.0	240.0	F5	43,613.00



Designed for harsh environments.

Digital Flow Meters



Commercial Products



Schedule 40

Order #	Description	List Price
7411500004*	Flow Meter 1.5" Complete	\$ 1,554.00
7412000004*	Flow Meter 2.0" Complete	1,554.00
7413000004*	Flow Meter 3.0" Complete	1,554.00
7414000004*	Flow Meter 4.0" Complete	1,684.00
7416000004*	Flow Meter 6.0" Complete	1,684.00
7418000004*	Flow Meter 8.0" Complete	1,684.00
7411000004*	Flow Meter 10.0" Complete	1,710.00
7411200004*	Flow Meter 12.0" Complete	1,710.00

*Please Note: Flow Meter comes with panel mount, saddle kit, transformer, cable, and sensor.

Schedule 80

Order #	Description	List Price
7411500008*	Flow Meter 1.5" Complete	\$ 1,554.00
7412000008*	Flow Meter 2.0" Complete	1,554.00
7413000008*	Flow Meter 3.0" Complete	1,554.00
7414000008*	Flow Meter 4.0" Complete	1,684.00
7416000008*	Flow Meter 6.0" Complete	1,684.00
7418000008*	Flow Meter 8.0" Complete	1,684.00
7411000008*	Flow Meter 10.0" Complete	1,710.00
7411200008*	Flow Meter 12.0" Complete	1,710.00

*Please Note: Flow Meter comes with panel mount, saddle kit, transformer, cable, and sensor.

Optional Mounting Kits

Order #	Description	List Price
7430100000	Wall Mount Kit	\$ 123.60
7430200000	Pipe Mount Kit for 1.5" pipe	123.60
7430300000	Pipe Mount Kit for 2.0" pipe	123.60
7430400000	Pipe Mount Kit for 3.0" pipe	123.60
7430500000	Pipe Mount Kit for 4.0" pipe	123.60
7430600000	Pipe Mount Kit for 6.0" pipe	123.60
7430700000	Pipe Mount Kit for 8.0" pipe	123.60
7441400000	Pipe Mount Kit for 10.0" pipe	123.60
7441500000	Pipe Mount Kit for 12.0" pipe	123.60

EQUIPMENT PACKS

for Swim-Spas, In-ground Spas & Swim Pools



Features

- The ultimate two or three pump Speck Equipment Pack is compact, dependable, versatile, fully automatic, and the perfect match for a Badu® SwimJet System.
- Installation is made easy with this pre-wired and pre-plumbed equipment pack.
- The GFCI protected packs, mounted on our unique thermoplastic forklift base (4' x 4'), have all the needed features.
- Motor and Drive are protected against voltage spikes, phase imbalance and power surges.
- Speck Equipment packs can be fully customized to fit your needs.
- Speck 4.0 HP Model 21-80/33 GS swimjet pump, Speck 2.5 HP Model 72-V spa/maintenance pump, and/or Speck 0.75 HP Model S90-I maintenance pump.
- Cartridge filters (*choice of makes available*)
- Motorized maintenance valves (*Model 750 only*)
- 4", 3" or 2" PVC plumbing connections available
- Heater plumbing connections
- 2" unions on valves, filter and filter pump
- 3" unions on the Model 72-V
- 4" unions on the Model 21-80/33 GS
- Mounting hardware, stainless steel
- Control Box Features:
 - Weatherproof, lockable plastic box
 - 125 Amp load center, 4 wire service
 - GFCI protected through 60 amp main breaker
 - Line connections, heater 115V (for electronic ignition)
 - Line connections, lights 115V
 - Time Clocks
 - Air switches for equipment operation of: (varies by pack model)
 1. Lights
 2. Motorized valves - pool or spa function
 3. Swimjet pump
 4. Spa pump
 5. Maintenance pump



Model 750-42

Trademarks and Certifications



Spa/Maintenance pumps are UL listed and NSF compliant. Swimjet pumps are UL listed. The controls are NRTL Listed # E212034 (complies with UL 508A Standard)

Applications

- Perfect match for commercial swim spas (indoor & outdoors)
- In-ground spa & swim pools

Model 750-42

For Dual Body Swim-Spas and Spa & Swim Pool Combinations

This is a full feature, builder ready equipment pack. Fully equipped with a 4.0 HP Swimjet pump, 2.5 HP Spa pump, 0.75 HP Maintenance pump, 120 sq. ft. cartridge filter with heater, and light connections. Motorized valves, time clock, and unions. Pre-plumbed and pre-wired. All components are **GFCI** protected.

Pricing

Order #	Description	List Price
Call for part number	Speck Equipment Packs, fully customizable to fit your needs	On request



Example of the control box with Jandy® System. Designed to control pool and/or spa from in house or spa side.



Portable Filter System

Features

- The BKP Portable Filter clears up bad water problems quickly without wasting water, heat, and chemicals.
- All units are completely equipped and can be moved easily around a pool or to a different pool site.
- Speck 1.0 HP pump Model 433-II with large strainer basket.
- SureSafe™ filter lid closure eliminates air entrapments.
- A 50 ft. power cord with GFCI plug, 115V.
- Stainless steel electric cord bracket.
- ON/OFF switch at the pump
- A 25 ft. drain hose (1.5")
- 1.5" hose adaptors with stainless steel clamps.
- Harmsco Single Cartridge Filter
- All stainless steel cart construction.
- Wheels with ball bearings and non-marring rubber tires.
- Protective stainless steel brackets to help protect pump strainer and motor end.
- Also available with 50% larger cartridge for longer filter runs.
- Two year warranty on all parts, including normal wear of the mechanical seal. All single speed motors also carry a two year warranty. The Harmsco filter comes with its own 10 year prorated limited warranty.



433-II/BKP105

Trademarks and Certifications



CONFORMS TO
NSF/ANSI Std. 50

Intertek
3186644

Applications

- Perfect match for commercial use

Technical Data

Model Pump/Filter	Filtration Area	THP	Full Rate		Pipe Size	Height (Inches)	Shipping Weight
			HP	S.F.			
433-II/BKP105	105 sq. ft.	1.0	0.75	1.50	1.5"	46.0"	115 lbs.
433-II/BKP155	155 sq. ft.	1.0	0.75	1.50	1.5"	55.0"	125 lbs.

NOTE: Both models are packed in one carton on a pallet and shipped via truck line.

Pricing

Order #	Description	List Price
FC546-1100M-OCI	Speck Pump Model 433-II, 1.0 THP, 115V, 50' Power cord with GFCI plug, ON/OFF switch, 25' Drain hose, Harmsco BF 105 Filter and Cart.	\$ 3,814.00
FC546-1100M-OCJ	Speck Pump Model 433-II, 1.0 THP, 115V, 50' Power cord with GFCI plug, ON/OFF switch, 25' Drain hose, Harmsco BF 155 Filter and Cart.	4,006.00

Commercial Filters

Filters & Systems



Horizontal Filters

Order #	Description	List Price
2228075	Micron Horizontal 42" x 75" 19.6 SF	On request
2228091	Micron Horizontal 42" x 91" 24 SF	
22280106	Micron Horizontal 42" x 106" 28.2 SF	
22280120	Micron Horizontal 42" x 120" 32.2 SF	
2229075	Micron Horizontal 48" x 75" 22.1 SF	
2229091	Micron Horizontal 48" x 91" 27.6 SF	
22290106	Micron Horizontal 48" x 106" 32.4 SF	
22290120	Micron Horizontal 48" x 120" 37 SF	

Please Specify M/H Left or Right when ordering



M-Series Filters

Order #	Description	List Price
22290104USA	Micron Horizontal M2500 50" x 88" w/4" ANSI 4 BAR 27.5 SF	On request
22290154USA	Micron Horizontal M3750 50" x 127" w/6" ANSI 4 BAR 38 SF	
22290200USA	Micron Horizontal M5000 50" x 166" w/6" ANSI 4 BAR 51.4 SF	



MD-Series Filters

Order #	Description	List Price
222905000USA	Micron Deep MD5000 79" x 128" 4 BAR, w/6" 54.5 SF	On request
222905500USA	Micron Deep MD5500 79" x 128" 4 BAR, w/8" 59.5 SF	
22290254USA	Micron Deep MD6500 79" x 148" 4 BAR, w/8" 71 SF	
222908000480US	Micron Deep MD7900 79" x 178" 4 BAR, w/8" 88.3 SF	
2229040410USA	Micron Deep MD10000 79" x 220" 4 BAR, w/10" 110 SF	



Vertical Filters

Order #	Description	List Price
22207248	HRV 24" MEDIA FILTER - 2" connections	On request
22207248A	HRV 24" MEDIA FILTER - 2" connections with 2" Valve	
22207308	HRV 30" MEDIA FILTER - 2" connections	
22207308A	HRV 30" MEDIA FILTER - 2" connections with Valve	
22207368	HRV 36" MEDIA FILTER - 2" connections	
22207368A	HRV 36" MEDIA FILTER - 2" connections with Valve	

Commercial Filters

Filters & Systems



SM-Series Filters

Order #	Description	List Price
220042341	SM1050 42" - 3" connections 58 PSI	On request
220048241	SM1200 48" - 3" connections 58 PSI	
TBD	SM1200 48" - 4" connections 58 PSI	
2200366584USA	SM36 - SIDE MOUNT FILTER - 8" NECK SHORT w/ 2.5" connections	
2200368084USA	SM36 - SIDE MOUNT FILTER - 8" NECK SHORT w/ 3" connections	
22004280124USA	SM42 - 42" SIDE MOUNT FILTER - 12" NECK w/ 3" connections	
22004880124USA	SM48 - 48" SIDE MOUNT FILTER - 12" NECK w/ 3" connections	



SMDD-Series Filters - (48" Bed Depth)

Order #	Description	List Price
224910508014USA	SMDD1050 42" Deep Bed Filter - 3" connections 58 PSI	On request
224912008014USA	SMDD1200 48" Deep Bed Filter - 3" connections 58 PSI	
TBD	SMDD1200 48" Deep Bed Filter - 4" connections 58 PSI	
2249140010014USA	SMDD1400 55" Deep Bed Filter - 4" connections 58 PSI	
2249160010014USA	SMDD1600 63" Deep Bed Filter - 4" connections 58 PSI	
224918041501USA	SMDD1800 71" Deep Bed Filter - 6" connections 58 PSI	
2249200015041	SMDD2000 79" Deep Bed Filter - 6" connections 58 PSI	
22492200154USA	SMDD2200 88" Deep Bed Filter - 6" connections 58 PSI	
22492350154USA	SMDD2350 93" Filter - 6" connections 58 PSI	
TBD	SMDD2350 93" Filter - 8" connections 58 PSI	
22492500154USA	SMDD2500 99" Filter - 6" connections 58 PSI	
TBD	SMDD2500 99" Filter - 8" connections 58 PSI	



Multicyclone Centrifugal Pre-Filter

Order #	Description	List Price
200392	Multicyclone 70XL - 4" connections	On request



Accessories

Order #	Description	List Price
W22345	Dual Pressure Gauge - Differential Pressure	On request

Also Available Manifolds, Valves, Piping Supports, Stacking, Metal Racking, Actuators, and Controllers

Filters

for Aquaculture & Koi Ponds



S-Series - Top Mount Sinking Beads Filters

Order #	Description	List Price
2201204B	S500 20" MICRON BEAD FILTER - 50 PSI w/ 1.5" Valve	On request
2201244B	S600 24" MICRON BEAD FILTER - 50 PSI w/ 1.5" Valve	
2201304B	S750 30" MICRON BEAD FILTER - 50 PSI w/ 2" Valve	
2201364B	S900 36" MICRON BEAD FILTER - 50 PSI w/ 2" Valve	

ExoTuf - Top Mount Sinking Beads Filters

Order #	Description	List Price
2260206B	E500 20" EXOTUF BEAD FILTER w/ Valve	On request
2260246B	E600 24" EXOTUF BEAD FILTER w/ Valve	
2260249B	E602 24" EXOTUF PLUS BEAD FILTER - 8" DEEP BED CLAMP TANK TOP MOUNT w/ Valve	
2260299B	E702 28" EXOTUF PLUS BEAD FILTER - 8" DEEP BED CLAMP TANK TOP MOUNT w/ Valve	

SM-Series - Side Mount Floating Bead Filters

Order #	Description	List Price
220008204B	SM500 20" FLOATING BEAD FILTER w/ Multi-port Valve	On request
220058244BD	SM600 24" FLOATING BEAD FILTER w/ Multi-port Valve	
220008304B	SM750 30" FLOATING BEAD FILTER w/ Multi-port Valve	
220008364B	SM900 36" FLOATING BEAD FILTER w/ Multi-port Valve	
220283610B	SM900 36" FLOATING BEAD FILTER - Black w/ 10" Neck & 2" Valve	
220042241B	SM1050 42" COMMERCIAL BEAD FILTER - w/ 3" Connections	
220048241B	SM1200 48" COMMERCIAL BEAD FILTER - w/ 3" Connections	

SM-Series - Side Mount Sinking Bead Filters

Order #	Description	List Price
220008204BS	SM500 20" SINKING BEAD FILTER w/ 1.5" Multi-port Valve	On request
220058244BS	SM600 24" SINKING BEAD FILTER w/ 2" Multi-port Valve	
220008304BS	SM750 30" SINKING BEAD MICRON FILTER w/ 2" Multi-port Valve	
220008364BS	SM900 36" SINKING BEAD MICRON FILTER w/ 2" Multi-port Valve	
220283610BS	SM900 36" SINKING BEAD FILTER - Black w/ 10" Neck & 2" Multi-port Valve	

Innovation & Service
for over 100 years.



SPECK 
pumps

8125 Bayberry Road
Jacksonville, FL 32256 USA

info.usa@speck-pumps.com
www.speck-pumps.com

Toll Free 800.223.8538
Phone 904.739.2626
Fax 904.737.5261